



Our Ref: Quote #: LP46ACO3458
 Assessment #: FCO-1303

CSR Building Products Limited
112 Wisemans Ferry Road
Somersby, NSW, 2500

Attention: John Trenerry

FIRE RESISTANCE OF FLOOR SYSTEM WITH CSR HEBEL POWERPANELS
Assessment Number FCO-1303
Your email of 15 April.

INTRODUCTION

As requested in your email we have re-analysed the data referenced by you on the likely fire performance of your floor system consisting of autoclaved aerated concrete Hebel Powerpanels screw fixed to timber joists.

The information included:

- CSIRO sponsored investigation report numbered FSV 0356 on a fire test conducted on 22 February 1995
- CSIRO assessment numbered FCO-1081, dated 12 September 2000;
- your fax dated 26 November 1996;
- your drawings numbered SK 009 1 and SK 009 2 dated 7 November 1996; and
- your fax dated 30 August 2001.

We have retained these documents and information.

You have requested this Division to re-assess the likely fire performance of your floor system consisting of autoclaved, aerated concrete Hebel Powerpanels of 75 mm minimum thickness, screw fixed to the top side of timber joists.

THIS ASSESSMENT SUPERSEDES THAT DATED 9 OCTOBER 2001

ANALYSIS

On 22 February 1995 this Division conducted a fire-resistance test on a 75 mm thick Hebel wall Powerpanels screw fixed to top hat section, which was screw fixed to a timber frame. The specimen comprised a timber frame of 70 mm x 35 mm F5 soft wood studs at 430 mm centres. The top plate was bolted to the specimen-containing frame. The bottom plate was fixed with masonry anchors to the brick infill at the lower edge of the specimen. Steel top hat sections, were fixed horizontally to the timber frame. The Powerpanels were fixed to the top hat section with 3 screws, the individual panels were fixed with two screws through the top, three screws through the middle and two screws through the lower top hat section. The unexposed face was clad with 10 mm CSR plasterboard.

The tested specimen achieved a fire-resistance level (FRL) of 240/180/180.

On 12 September 2000 this Division issued letter of opinion numbered FCO-1081 which included chart for the rise in temperature of reinforcement with various thicknesses of autoclaved, aerated concrete cover and the residual yield strength of the reinforcement as percentage of its strength at ambient temperature. In conclusion we expressed the opinion that steel reinforced wall and slabs of CSR Hebel autoclaved, aerated concrete, designed using the graphs supplied, would be capable of achieving the fire-resistance levels derived from those graphs if they were subjected to test conditions of AS 1530.4-1997

From the graph in FCO-1081, insulation period verses thickness, 75 mm thick autoclaved, aerated concrete Hebel Powerpanels would be capable of providing insulation for up to 240 minutes, provided that:

1. the autoclaved, aerated concrete panels are designed in accordance with the recommendations given in FCO-1081;
2. the timber joists are insulated from fire; and
3. in the design of timber joists, the thickness and or the stresses are factored in, to allow for temperature affects,

and the floor system would be capable of withstanding fire exposure from above for up to 240 minutes without failure.

CONCLUSION/OPINION

Based on the factors detailed above it is the opinion of this Division that:

- (i) the floor system consisting of autoclaved, aerated concrete Hebel Powerpanels, 75 mm minimum thickness, screw fixed to the top of timber joists at 450 mm centres, and constructed as detailed in your drawing numbered SK 009 1; and
- (ii) the floor system consisting of autoclaved, aerated concrete Hebel Powerpanels, 75 mm minimum thickness, screw fixed to the top of timber joists at 600 mm centres, and constructed as detailed in your drawing numbered SK 009 2

would be capable of withstanding standard fire exposure for up to 240 minutes, provided that, the panels are designed in accordance with the recommendations given in our opinion numbered FCO-1081, and the fire is from above the floor slab.

Note: The fire from above is a non-standard form of fire exposure for floor slabs.

This Division has examined the fire performance of the floor system for fire from above only and had not examined the structural adequacy or the permissible loading on the timber joist.

TERM OF VALIDITY

This opinion will lapse on 30 April 2013. Should you wish us to re-examine this opinion with a view to the possible extension of its term of validity, would you please apply to us three to four months before the date of expiry. This Division reserves the right at any time to amend or withdraw this opinion in the light of new knowledge.

Yours faithfully,



Garry E Collins
Manager, Fire Testing & Assessments

9 April 2008

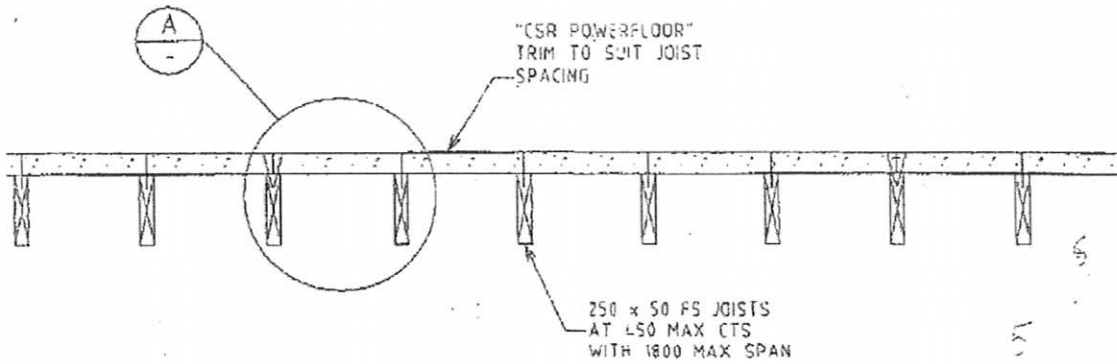

SECTION ALONG "CSR POWERFLOOR"

SCALE 1:20

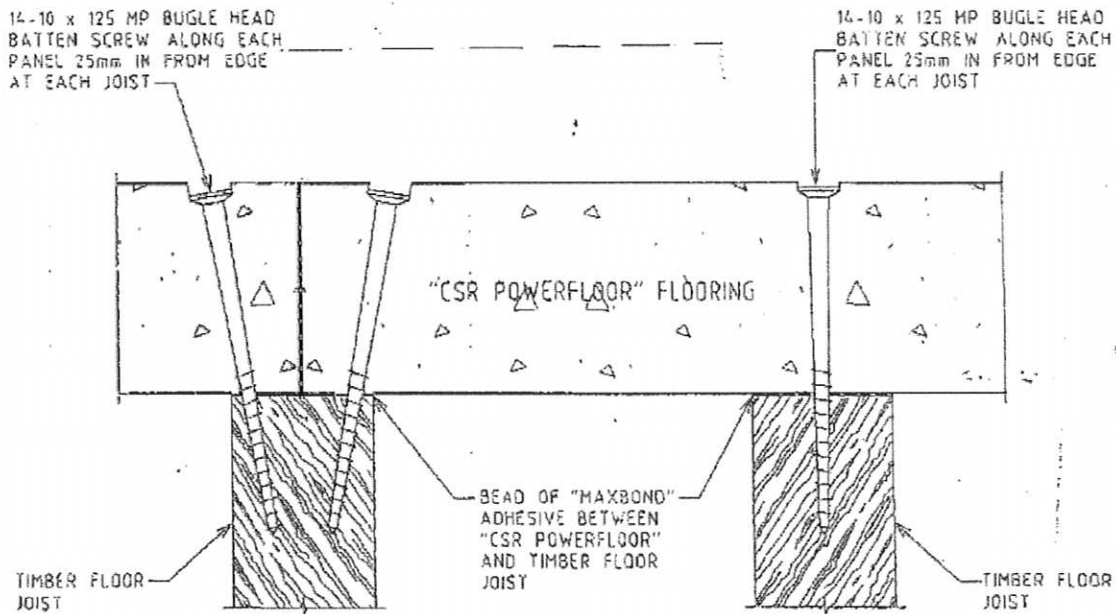

DETAIL

SCALE 1:2

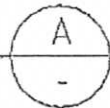

Hebel

CSR Building Quality
Level 5, 5 Help Street,
Cherrywood NSW 2067
Phone: (02) 9372 5400
Fax: (02) 9372 5422

"CSR POWERFLOOR"
FIRE TEST WITH JOISTS
AT 450 CENTRES MAXIMUM

DRAWN	DESIGN	CHECKED	DATE	SCALE
JML	JRD	JY	7/11/96	1:20 1:2

DWG No.
SK 009 1

REVISIONS

NO.	DESCRIPTION
A	

THIS ASSESSMENT SUPERSEDES THAT DATED 9 OCTOBER 2001

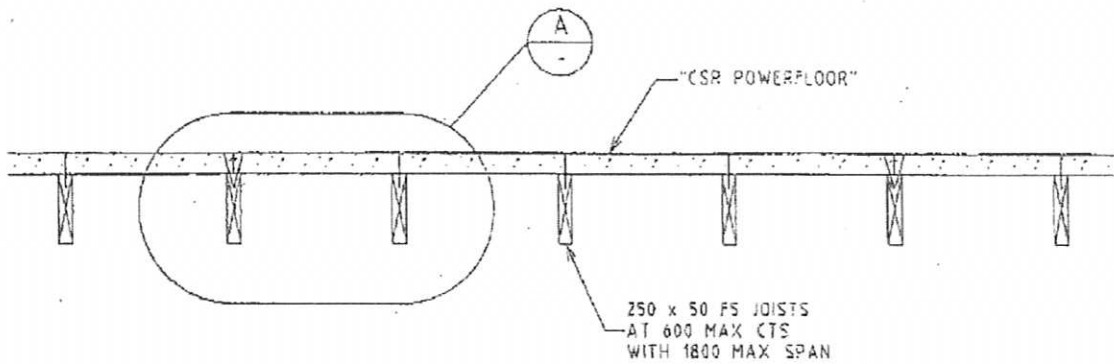

SECTION ALONG "CSR POWERFLOOR"

SCALE 1:20

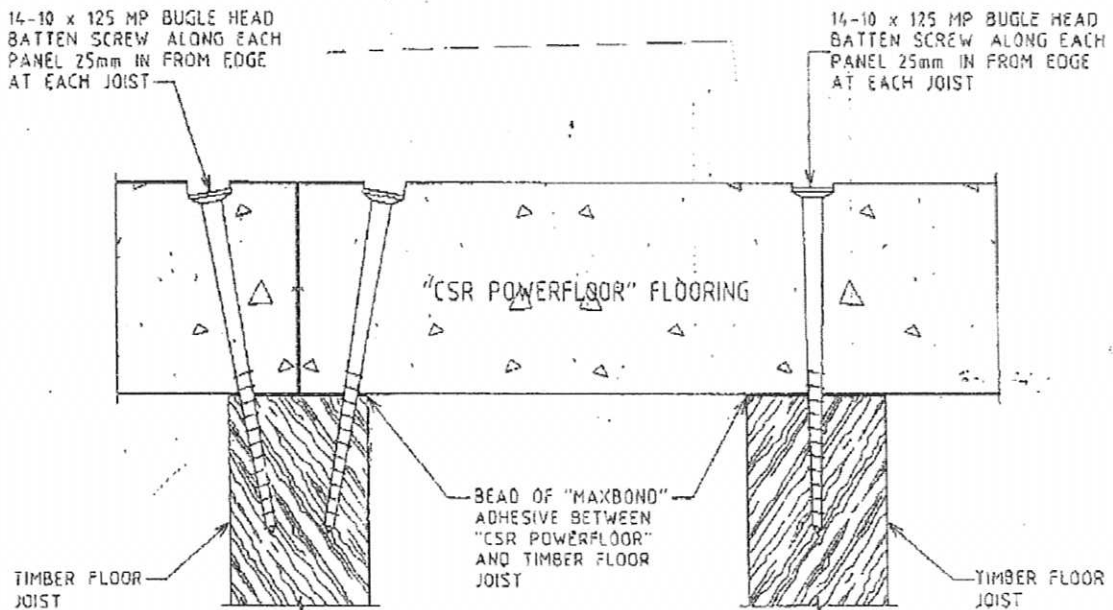

DETAIL

SCALE 1:2

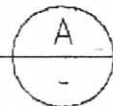

CSR BUILDING BY IN QUALITY

Hebel

CSR Hebel Australia Pty Ltd
 Level 6, T Holo Street,
 Chatswood, NSW 2087
 Phone: 102 19372 3400
 Fax: 102 19372 5422

"CSR POWERFLOOR"
 FIRE TEST WITH JOISTS
 AT 600 CENTRES MAXIMUM

DRAWN	DESIGN	CHECKED	DATE	SCALE
DPL	JRD	JY	7/11/96	1:20 1:2

DWG No.
SK 009 2

REVISIONS

NO.	DESCRIPTION
A	

THIS ASSESSMENT SUPERSEDES THAT DATED 9 OCTOBER 2001